



## SlimStile BA

### Tripod Turnstile for Internal Installation

Tripod Turnstiles are compact and cost-effective entrance solutions designed for smooth and silent operation, less wear and tear and reduced power consumption, suitable for areas where there is a large flow of people.

The SlimStile BA, our stainless steel compact version, offers high operating reliability in a small casework for wall-mounted or pedestal installation, ideal for sites where space is an issue. On receiving a signal from the access control system, or push button, it allows the passage of one person at a time. The status is shown on the led-way mode indicators, in entry and exit side.

Passage in both directions is electronically controlled. Available in normally closed configuration to lock the mechanism until a valid authorisation signal is received, or available in normally open configuration to lock the mechanism in the event of attempted unauthorised entry. The normally open configuration allows also reduced power consumption and increases the life of the mechanism and passage through put speed. In case of emergency, the hub can freely rotate to allow an easier exit. You can also choose the drop arm option which automatically drops the horizontal arm to allow free passage. Led way mode indicators included as standard. External installation allowed under canopy.



# SlimStile BA

Technical Specifications

## Drive

Hand-operated

## Materials

Casework: #4 grade grained stainless steel  
 Casework lid: #4 grade grained stainless steel  
 Tripod hub: Cast aluminum with painted grey finish  
 Tripod arms: 1.50" dia. 18.90" #4 polished stainless steel

## Mechanism

Electro-mechanical head mechanism:

- Positive locking action for one passage at a time
- Self-centering mechanism to ensure complete rotation
- Hydraulic damper to ensure smooth operation
- Anti-backup device to prevent reverse rotation once the mechanism has moved 60° from home

## Power Failure/Fire Alarm

Either one or both directions can be fail-safe (standard), i.e. rotates freely, or fail-lock, i.e. locks in the home position.

Fire alarm – emergency input. Input facility available for free voltage contact to effect fail state.

Mechanism fail state will be the same as power failure choice.

Drop arm option: the horizontal arm drops to create a clear passage for evacuation.

## Interface

LL2001Lite microprocessor control logic:

- One input for opening/locking in each direction
- Two protected outputs controlling opening/locking
- Four protected outputs piloting way mode indicators
- Two protected outputs counting passage in either directions
- Two 0V output relays indicating availability of use or counting passage in either direction
- Two open collector NPN outputs to count passage or to indicate availability of use in either direction or activate the optional drop arm feature
- Serial Port – RS485

## Power Supply/Power Rating

115 Vac 60Hz. Power Rating 50VA (stand by 5VA if Normally Open).

## Operating Temperature/IP rating/MCBF/MTTR

32 to +113F/ IP 20 / 1.5m cycles (2.5M if Normally Open) / less than 30 min

## Flow Rates (approximate figures)

Insertion Type Reader: 20 passages per minute

Swipe Type Reader: 30 passages per minute

Proximity Reader "Hands Free": 40 passages per minute

## Models or Versions

- Pedestal-mounted
- Wall-mounted

## Options

- Card reader mounting
- Remote control MP2000
- Push button control
- Pictograms
- LCD counter
- Drop arm

## Applications

- Government
- Retail
- Finance
- Telecommunications
- IT
- Banking
- Publishing
- Leisure
- Petrochemical
- Education

# SlimStile BA

## Site Preparation

Product delivered fully assembled and may require lifting equipment. Approx. weight: 88lbs, wall mounted 57lbs  
(For installation details, please refer to the proper installation layout drawings) - Dimensions shown in inches and millimeters

### Pedestal mounted version & wall mounted version

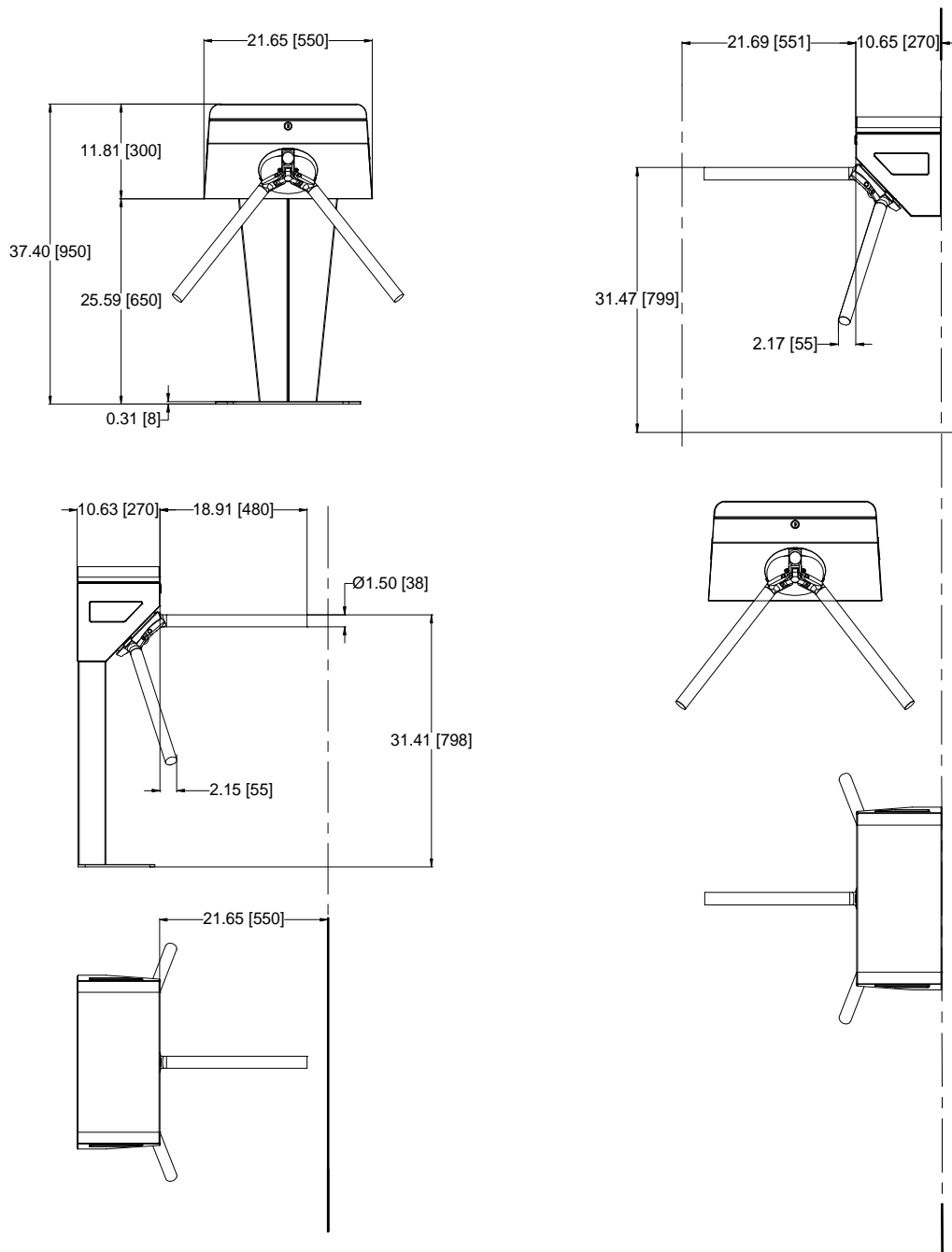

Base to be flat and level to +/- 0.20" over footprint area. Dimensions to be > 28" x 20" x 6" deep min (pedestal version).

# SlimStile BA

## Important

- Any horizontal pipe or conduit running below the Tripod Turnstile must be at least 5.5" below FFL.
- Metal conduit for cables should be raised at least 2" from foundation.
- It is the customer's responsibility to ensure the structural integrity and strength of the installation location.
- The dimensions given in this Product Data Sheet are for information only.

**For further information please contact:**

Gunnebo Entrance Control Inc  
535 Getty Court, Suite F  
Benicia, CA 94510

Tel 707 748 0885

Fax 707-745 6020

E-mail: [info@gunnebo.us](mailto:info@gunnebo.us)

Web: [www.gunnebo.us](http://www.gunnebo.us)

Note: In pursuit of its policy of continuous refinement and improvement, Gunnebo Competence Centre Entrance Control reserves the right to modify design and details at any time and without notice.