

HMI Touchscreen Controller

Human Machine Interface – Desktop Remote Touchscreen

Tailored to Your Needs

As a world leader in entrance control solutions, Gunnebo has always looked to supporting our customers to not only provide the physical deterrent against unauthorized access but also a means to control each installation locally.

Gunnebo's HMI (Human Machine Interface) Controller is a touchscreen, software-based controller which offers benefits to coincide with each turnstile application. From password protection, lane counts, alarm counts, on-the-go configuration changes to troubleshooting, the HMI is an advantageous tool in support of your security goals.

Although each turnstile lane can be controlled via the current access control system through timing values, the HMI controller allows each area to be controlled with quickly and with precision. Managing visitors, delivery personnel, and ADA requirements has never been easier.

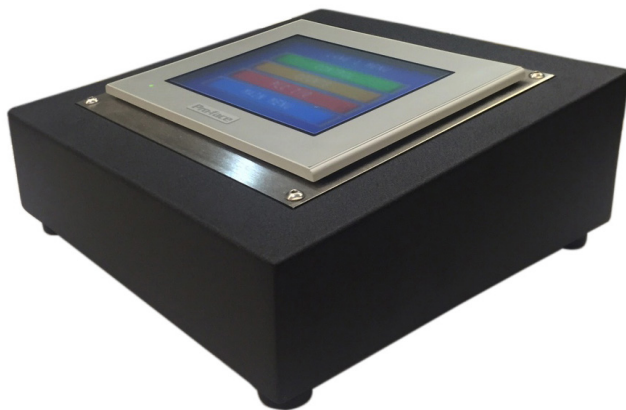

HMI Product Advantages

- Standalone sleek design
- Password protected
- Ability to control each lane individually
- Active count total to facilitate reporting
- Turnstile diagnostic assistance
- On-the-fly configuration changes
- Remote accessible
- Controls a maximum of 8 lanes per HMI
- Color screen



Application Type and Function

The HMI touchscreen controller is designed to support Gunnebo's line of optical turnstiles. It can be installed as a standalone unit or customized to fit within a security desk or anywhere else where functionality and immediate control is required.

The HMI controller is password protected as standard, making sure that the controller can't be tampered with and only trained personal have access to its entrance/exit functionality. To further assist the security staff, the HMI keeps an active count of all entries/exits and alarm conditions. In addition, the HMI Touchscreen allows the user to change turnstile configurations and modes on the fly, along with providing troubleshooting data for the system's service provider.

HMI Touchscreen Controller

Human Machine Interface – Desktop Remote Touchscreen

SCREEN VIEWS & DIMENSIONS

The HMI Touchscreen Controller provides the necessary controls to access the lanes and control traffic flow. It also provides real-time statistics on entry, exit, alarm, and tailgating.

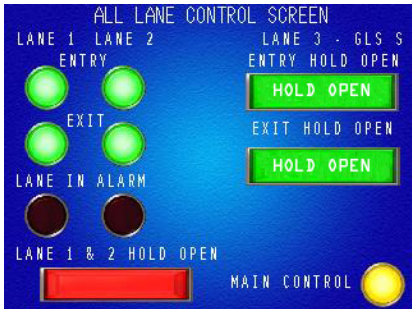

All Lane Control Screen



Lane 1 Operation Menu

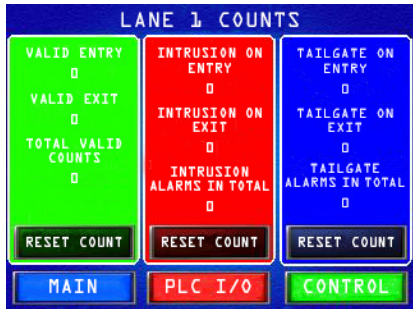

Lane 1 Counts Screen

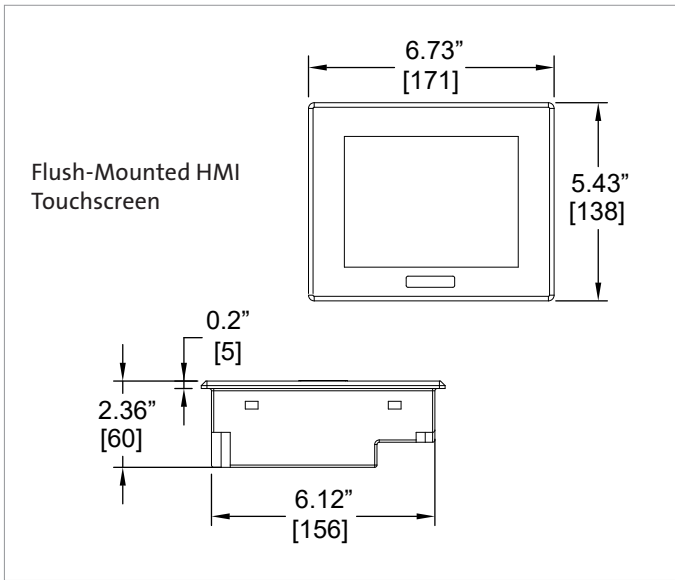

Flush-Mounted HMI Touchscreen

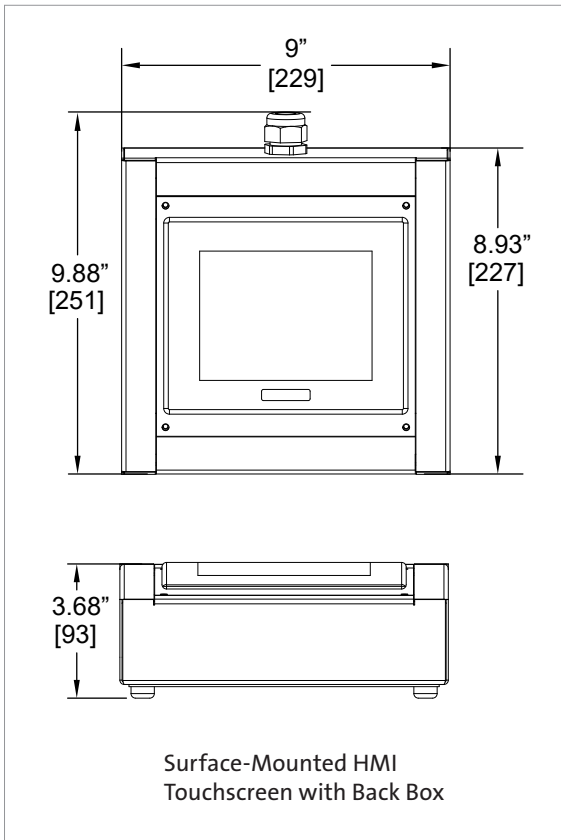

Surface-Mounted HMI Touchscreen with Back Box

For further information, please contact:

Gunnebo Entrance Control Inc.
 535 Getty Ct., Benicia, CA 94510
 Tel: 513-666-4821
 Email: info@gunnebo.us

Note: In pursuit of its policy of continuous refinement and improvement, Gunnebo Entrance Control reserves the right to modify design and details at any time and without notice.